

MON4-3

Compact Dual-Standard Quad 4" LCD Color Monitor



Description

MON4-3 is a quad 4" LCD color video monitor. The standard version has 4 composite video inputs (NTSC and PAL autosensing). Each BNC composite video input has a passive loop-through and a 75 ohm termination switch. The high quality LCD chassis offers adjustable viewing angles for efficient operator viewing.

Optional field-installable SDI modules may be added (one per LCD screen), each one provides an SDI video input channel with a reclocked SDI video output and a converted composite video output. The SDI Module also offers color bars with a rear-panel switch.

Optional field-installable additional composite video input with passive loop-through may be ordered providing a A/B switching facility with front panel control. Optional RGB input with synch. on green is now also available.

Built-in Red/Green tally lights from DB25 connector on the rear panel can be interfaced to most tally systems. The MON4-3 has front panel trim pot controls for Color, Tint/Hue, Brightness and Contrast.

The MON4-3 is ideal for confidence video monitoring of multiple video feeds for mobile trucks, news and transmission control rooms, duplication and post production applications. Built and rigorously tested in the USA, the MON4-3 is backed by a strong warranty and a "Satisfaction Guaranteed" return policy.

Features

- Quad 4" LCD Color Video Monitor
- Adjustable Screen Angle for Efficient Viewing
- Four Composite Video Inputs with Loop-Through
- Optional Additional Composite Inputs for A/B Switching (Optional Remote Capability)
- Optional (Field Installable) SDI Input Module With re-clocked SDI and Converted Analog Monitoring Outputs
- RGB Inputs available as an Optional Extra
- Mix & Match Analog and Digital Video Inputs
- Front Panel Trim Pot Control for Color, Tint/Hue, Contrast And Brightness
- Dual Standard NTSC/PAL Auto-Sensing With Front Panel Indication
- Red/Green Tally Lights
- Minimal Power Dissipation for a Low Operating Temperature
- Low Power Consumption
- Front Panel A/B Switching with Remote Capability
- Internal Universal AC Mains Power Supply

MON4-3

Compact Dual-Standard Quad 4" LCD Color Monitor

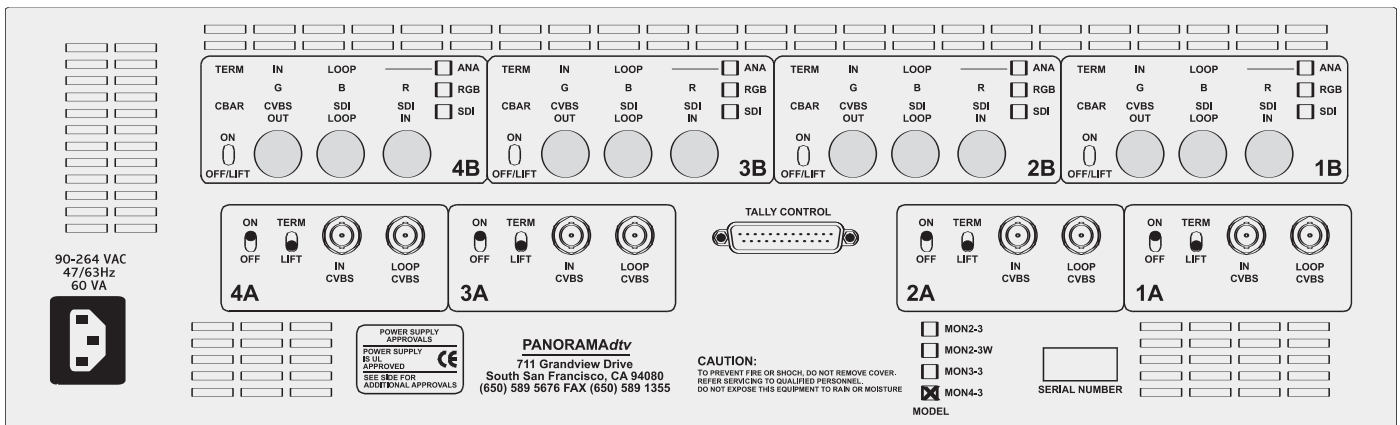

Specifications

| | | | |
|---------------------------|--|---------------------|---|
| Video input | 4 composite video inputs, 1 per screen | Dot pitch | 0.171 x 0.264mm |
| Video input termination | selectable 75 ohm termination | Color configuration | RGB stripe |
| Video output | 4 loop-through composite video outputs, 1 per screen | Viewing angle | top=10°, bottom=30°, left=45°, right=45° |
| Screen size | 4" diagonal | Contrast ratio | 150 (typ.) |
| Screen type | active matrix TFT | Brightness | 300 NITs (cd/m ²) |
| Source selection | A/B selection with optional extra SDI or composite modules | LCD lamp life | 15,000 hours (avg.) |
| Display modes | NTSC/PAL autosensing | Chassis type | 3U, 19" rack mounting (EIA-310D) |
| Aspect ratio | 4:3 | Dimensions (HxWxD) | 19 x 7.125 x 5.2" (483 x 132 x 181mm) |
| LCD active area | 82.1 x 61.8mm | Weight | 12.3lbs (5.6kg) |
| Picture controls | brightness, chroma, tint & contrast | Power consumption | 23W |
| Resolution (dots x lines) | 480 x 234 | Power supply | 100 to 240VAC, 50/60Hz, universal input CE & UL approved internal power supply |

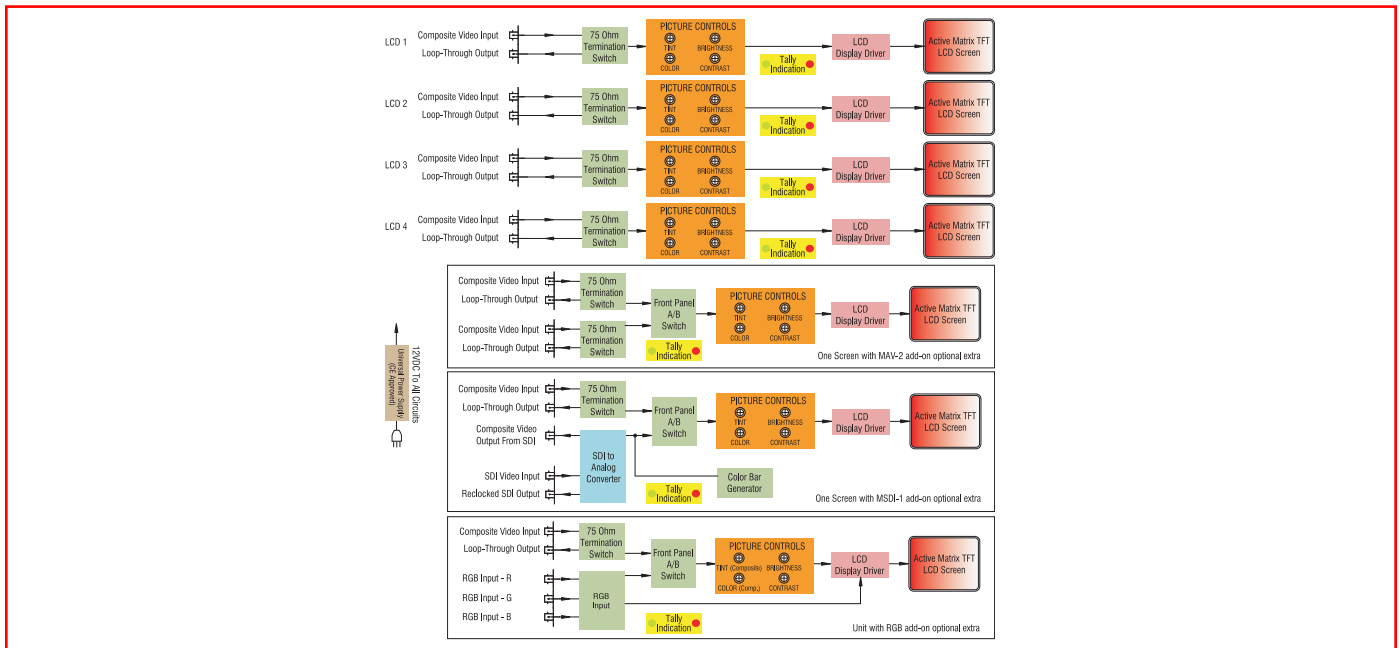

Toll Free (US) 1-888-596-4537 Phone 510.870.0810 | Fax 510.870.0811

31055 Huntwood Avenue, Hayward, CA 94544 USA

www.panoramadt.com | sales@panoramadt.com

Wohler Technologies Inc., is registered trademark. All other trademarks are registered trademarks for their respective companies.