

# BPS-2020

## DIGITAL BYPASS SWITCHER



The BPS-2020 Digital Bypass Switcher is an 8x1 switcher for digital video (SD or HD) and digital audio signals. Designed for use in conjunction with the Utah Scientific MC-2020, the BPS-2020 provides a compact, reliable means for switching alternate signals into the program feed, thus bypassing the various elements in the master control signal chain.

### BPS-2020 FEATURES

- Eight Inputs -- SD/HD Digital Video and up to four AES levels
- Dual redundant power supplies are standard equipment
- Optional input loop-through feature
- Space-saving 2 RU package
- Multiple options for remote control

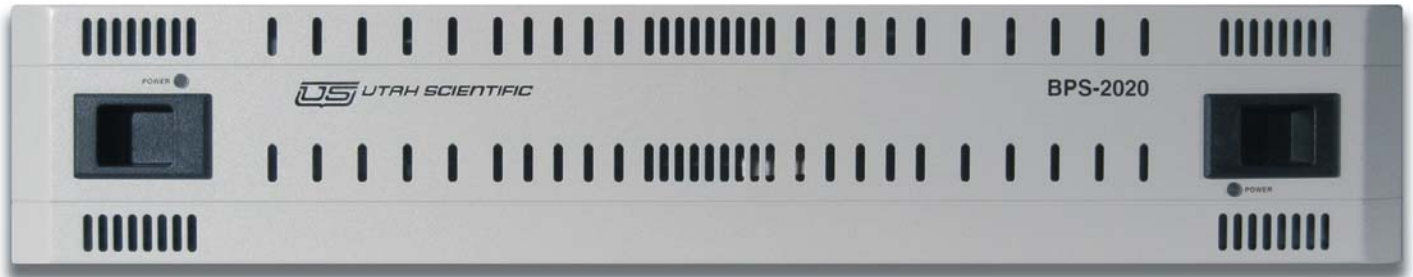

The BPS-2020 is housed in a 2ru frame with redundant power supplies. The supplies are the same as those used in the MC-2020 to simplify system maintenance requirements.

The BPS-2020 frame holds a main video switcher board with on-board control logic, an optional video DA board to provide looped copies of each input if required, and one or two audio switch boards, each of which will handle two AES signal streams.

## VIDEO

The video switcher section will handle digital video streams at any rate from 1.5Mbps to the full HD rate of 1.485Gbps. The eight inputs have cable equalization for up to 1,000 ft of cable at 270Mbps. There are two re-clocked video outputs provided, one for the main program feed and one for monitoring. The monitor output has inverted polarity so care should be taken when using it for other purposes.

The optional Video DA board provides actively regenerated loop-through connections for each of the eight inputs.

## AUDIO

The main audio switcher board has eight inputs for two levels of AES/EBU digital audio signals. The optional second audio switch board provides switching for two additional AES/EBU levels. The input and output connections are 110 Ohm balanced. Utah Scientific offers several different models of breakout panels to simplify wiring to the BPS-2020's I/O connectors or to provide unbalanced I/O signal connection capability.

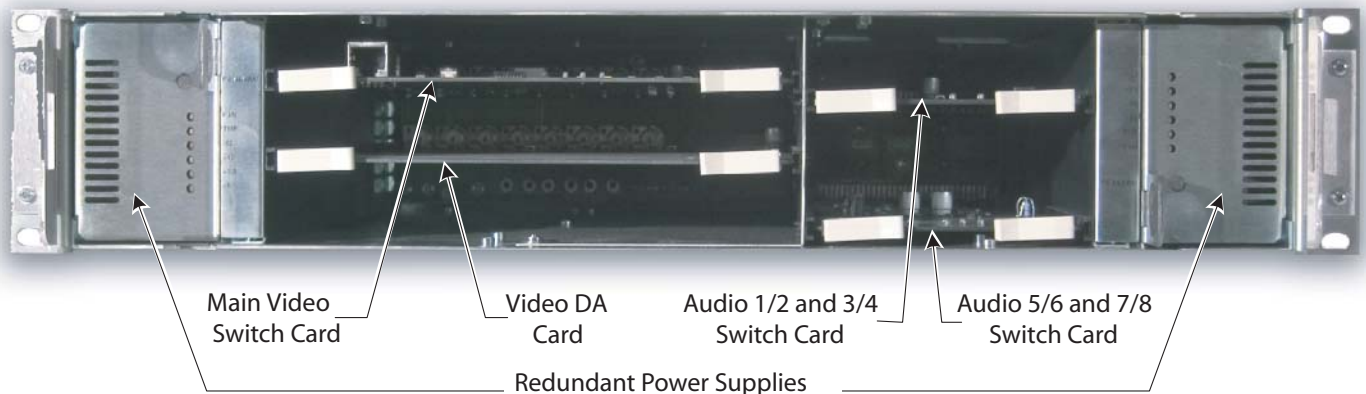

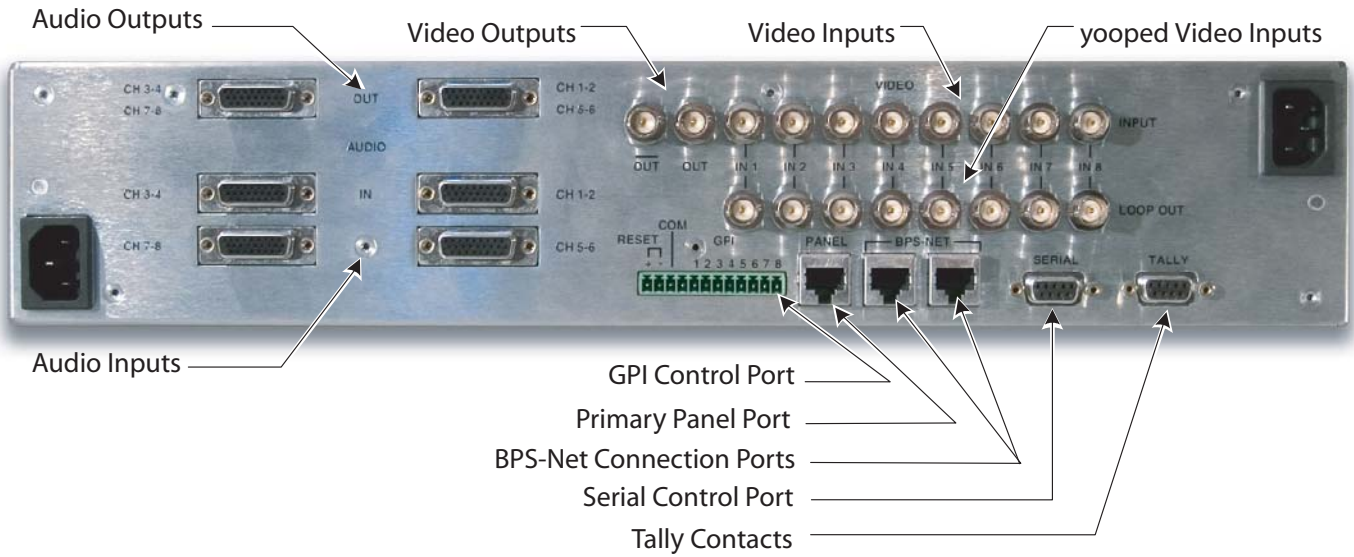

## CONTROL

There are a number of options available for control of the BPS-2020. For dedicated single-channel systems, a simple 8-button control panel is available. This panel is designed to mount adjacent to the associated MC-2020 control panel.



For multi-channel systems, an 8-channel panel allows the operator to select the channel to be controlled by the eight source select buttons on the panel.



To support custom-built control panels, GPI contacts are available for selecting the sources by a simple contact closure, and Tally (GPO) closures are provided to drive indicators showing the active source selection.

A serial port is also provided for connecting external control devices to the switcher, selecting sources through a very simple serial control protocol. Both Utah's RCP-1 and the GVG-10XL protocols are supported for communicating with this port.

The BPS-2020 can also be controlled directly from the MC-2020 control panel by programming the MC-2020's user-defined functions to drive the bypass switcher. Please contact Utah Scientific's technical support department for complete details on controlling the BPS-2020 Digital Bypass Switcher

## BPS-2020 Product Information Sheet

BPS-2020 PRODUCT SPECIFICATIONS		
Video Inputs:		8 ea (per SMPTE 259 or SMPTE 292)
Video Return Loss:		< 15dB at 1.485Gb/s
Switch Point Timing Control:		Referenced to the vertical interval of the current output signal
Video Outputs:		2 ea (monitor output is inverted)
		8 ea optional regenerated loop-throughs of the inputs
Digital Audio Inputs:		110 Ohm, Balanced 8 per level, 2 AES/EBU levels per switch card
Digital Audio Outputs:		110 Ohm, Balanced 1 per level
Mechanical Dimensions:		19"W x 22" D x 3.5"H (2 ru EIA rack mount)
Connectors:	Control Panel Port:	RJ-45 (CAN-Bus)
	Inter-frame Control:	RJ-45 (RS-422)
	Serial Port:	DB-9F Subminiature 9-pin D connector with female pins.
	Tally Connections:	DB-9F Subminiature 9-pin D connector with female pins.
	GPI Control:	Terminal Strip w/ removable mating block
	MC-500 Control Port:	DB-50F Subminiature 50-pin D connector with female pins.
	Video Connections:	BNC
	Audio Connections:	DB-25F Subminiature 25-pin D connector with female pins.
Environmental:	Temperature:	10-40°C
	Relative Humidity:	0-90% (non-condensing)
AC Power:	110 / 240VAC 50 / 60 Hz	Chassis consumption is 35 VA max. Dual redundant power supplies are standard equipment.



New Directions in Digital Switching

4750 Wiley Post Way Suite 150 Salt Lake City, Utah 84116  
 Phone: (801) 575-8801 Fax: (801) 537-3099  
 EMail: sales@utsci.com www.utahscientific.com