

Model AJ4E - AJ4EBI - AJ4E/INOX - AJ4E/IT

- High Power Version (H.P.)
- FM Band 87.5÷108 MHz
- Suitable for VHF, Band I and OIRT Band
- Gamma Match Tuned
- Omni directional pattern
- Vertical or horizontal polarization
- Light - Low Cost - Demountable

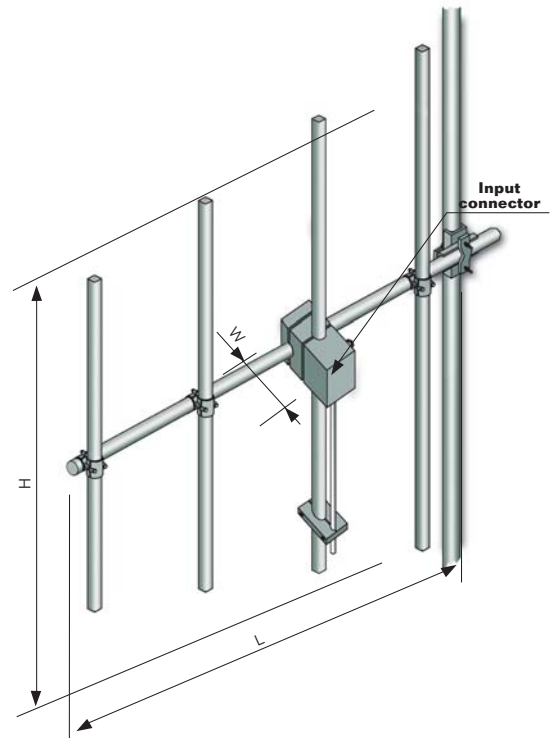

ELECTRICAL DATA	
Frequency range	87.5+108 MHz
Impedance	50 Ohm
Connectors	N or 7/16" female or 7/8" EIA
Max Power	650W (N) – 1300W (7/16" – H.P. Version)
VSWR	≤ 1.1:1 in the operating channel
Polarization	Vertical or horizontal
Gain	8 dB (referred to half-wave dipole)
Pattern	E plane ± 25° H plane ± 30°
Lightning protection	No DC grounded

MECHANICAL DATA	
Dimensions	According to the working frequency 1500 (H) x 2090 (L) x 100 (W) mm at 98 MHz
Weight	According to the working frequency (aluminium or stainless steel)
Wind surface	0.18 m ² (at 98 MHz)
Wind load	23.3 kg (wind speed at 160 km/h)
Max wind velocity	180 km/h (AJ4E/IT model)
Materials	AJ4E: Aluminium elements and boom AJ4EBI: Aluminium elements and stainless steel boom AJ4E/INOX: Stainless steel elements and boom AJ4E/IT: Stainless steel elements and boom Tig Welded Version Teflon insulator Radome: fiberglass (option)
Icing protection	Feed point radome (optional)
Radome	Optional
Mounting	With special pipe clamps 50÷110 mm dia.

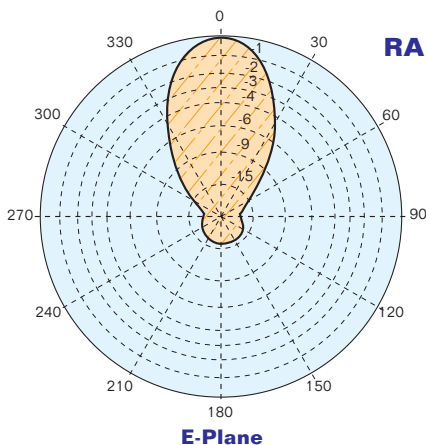

RADIATION PATTERN (MID BAND)

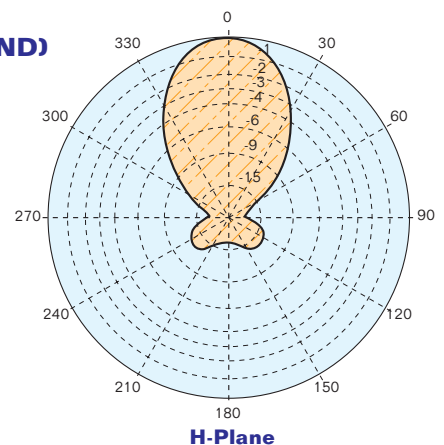

Model AJ4E - AJ4EBI - AJ4E/INOX - AJ4E/IT

Radiations systems with AJ4E antenna

Collinears systems



ELECTRICAL DATA	
Frequency range	87.5+108 MHz
Impedance	50 Ohm
Connector	EIA flange according to system power rating
VSWR	≤ 1.1:1 Max
Polarization	Vertical
Gain	According to requirement
Horizontal pattern	Any type according to requirements
Vertical pattern	Null fill, beam tilt and special requirements to order
Other facilities	The antenna system can be supplied in split feed with two equal half antennas. Each half can accept full power

MECHANICAL DATA	
Height of array	Subject to number of bays (refer to table)
Total net weight	According to the working frequency
Wind load	Refer to table (at 98 MHz)
Pressurizable	No
Radome	Optional
Mounting hardware	Hot dip galvanized steel clamps
Shipping	As required

Number of bays	Dipole per bay	Gain ¹		Weight ² kg	Antenna height L m	Wind load (v=160 km/h) kg
		dB	times			
1	1	8.0	6.3	-	1.5	23.3
2	1	11.0	12.6	-	4.1	46.6
4	1	14.0	25.2	-	9.3	93.2
6	1	15.8	37.8	-	14.5	139.8
8	1	17.0	50.4	-	19.7	186.4

¹ Referred to a half wave dipole. Attenuation of connecting cables not taken into account.

² Without mounting hardware.

- Gain is provided for vertical polarization.
- If the antenna is side mounted, the supporting structure will have a slight effect on the radiation pattern and VSWR.
- Vertical tower space, wind load and weight numbers given are typical. Actual values vary with the specific installation. Contact us for more details of your installation.
- Gain will be reduced if null fill, beam tilt or special wavelength spacing is provided.
- Antenna radiation aperture is the distance from the centre of the top bay to the centre of the bottom bay.
- Five ft(1.6m) of pipe required above the top bay and below the bottom bay for to protect from pattern interference by other antennas.
- Antenna wind load is calculated for 100 Mph (160Km/h) per EIA-222-C standard.

