

Model ACP1

- **Band II**
- **Broadband 87.5÷108 MHz**
- **Demountable**
- **Circular polarization**
- **Stainless steel AISI 304**
- **Pressurizable on request**

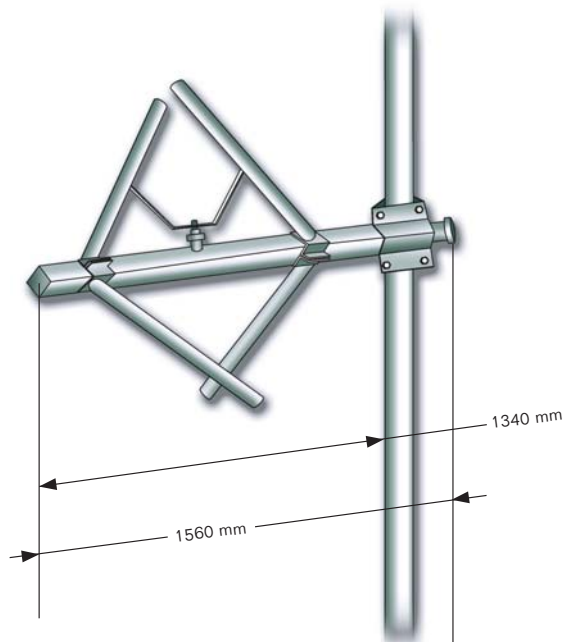

ELECTRICAL DATA	
Frequency range	87.5÷108 MHz
Impedance	50 Ohm
Connectors	N or 7/16" or 7/8" EIA
Max Power	800W (N) – 2KW (7/16") – 3KW (7/8" EIA)
VSWR	≤ 1.4:1
Polarization	Circular
Gain	Refer to table
Pattern	Omni directional ± 1.5 dB in free space Omni directional ± 3 dB with 100mm dia. pole
Lightning protection	All metal parts DC grounded

MECHANICAL DATA	
Dimensions	1560x1150x1150 mm
Weight	13 kg
Wind surface	0.19 m ² (side) 0.13 m ² (front)
Wind load	31.1 kg (side - wind speed at 160 km/h)
Max wind velocity	220 km/h.
Materials	External parts: stainless steel Internal parts: aluminium treated
Mounting	With special pipe clamps 50±110 mm dia.

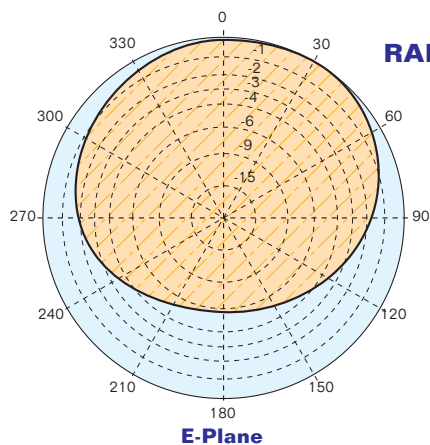

RADIATION PATTERN (MID BAND)

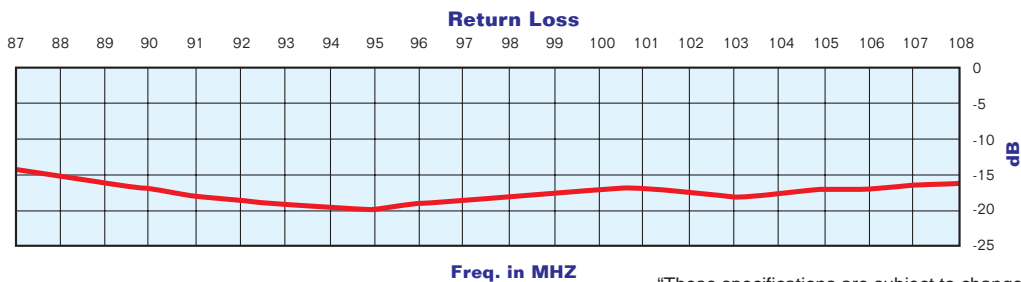
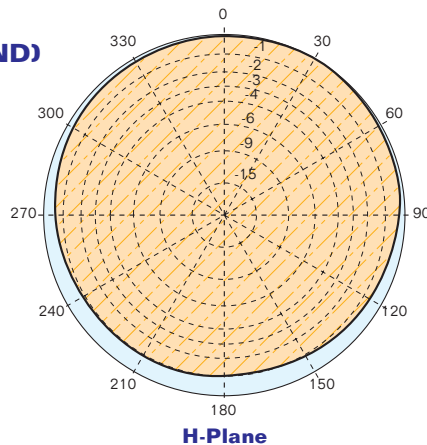

"These specifications are subject to change without notice"

Radiations systems with ACP1 antenna

Omnidirectional patterns

ELECTRICAL DATA	
Frequency range	87.5+108 MHz
Impedance	50 Ohm
Connector	EIA flange according to system power rating
VSWR	≤ 1.4:1 Max
Polarization	Circular
Gain	According to requirement
Horizontal pattern	Any type according to requirements
Vertical pattern	Null fill, beam tilt and special requirements to order
Other facilities	The antenna system can be supplied in split feed with two equal half antennas. Each half can accept full power

MECHANICAL DATA	
Height of array	Subject to number of bays (refer to table)
Total net weight	Refer to table
Wind load	Refer to table
Pressurizable	Yes (on request)
Mounting hardware	Hot dip galvanized steel clamps
Shipping	As required

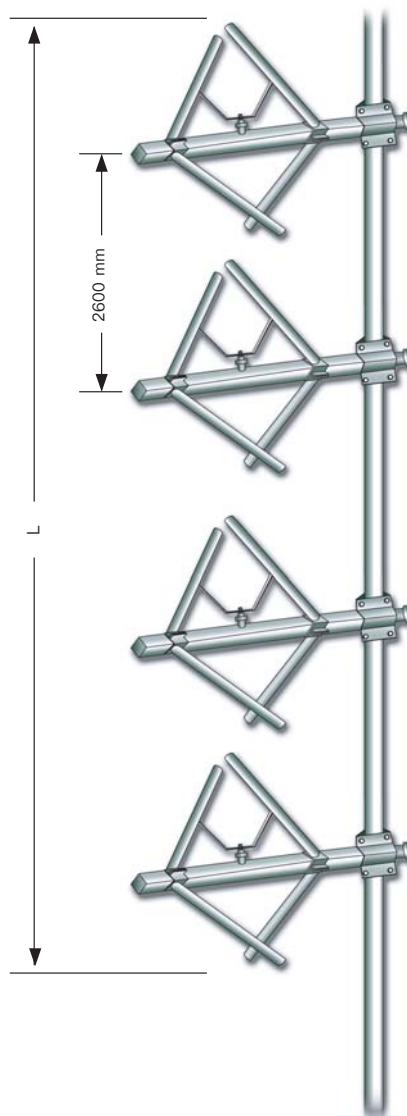

TECHNICAL DATA

Number of bays	Dipole per bay	Gain ¹		Weight ² kg	Antenna height L m	Wind load (v=160 km/h) kg	SYSTEMS MODELS ³			
		dB	times				2 KW	4 KW	6 KW	10 KW
2	1	-1.50	0.71	26	3.8	62.2	ACP1X22	ACP1X24	ACP1X26	-
3	1	0.27	1.06	39	6.4	93.3	-	-	-	-
4	1	1.50	1.42	52	9.0	124.4	ACP1X42	ACP1X44	ACP1X46	ACP1X410
6	1	3.28	2.13	78	14.2	186.6	ACP1X62	ACP1X64	-	ACP1X610
8	1	4.50	2.84	104	19.4	248.8	ACP1X82	ACP1X84	ACP1X86	ACP1X810
12	1	6.29	4.26	156	29.8	373.2	-	-	-	-

¹ Referred to a half wave dipole. Attenuation of connecting cables not taken into account.

² Without mounting hardware.

³ The systems comprised: antennas, cables and splitter – for more details to see catalog – different version on request.

- Gain is provided for vertical polarization.
- When antenna is pole mounted on the top a tower the horizontally polarized radiation pattern is omni - directional.
- If the antenna is side mounted, the supporting structure will have a slight effect on the radiation pattern and VSWR.
- Vertical tower space, wind load and weight numbers given are typical. Actual values vary with the specific installation. Contact us for more details of your installation.
- Gain will be reduced if null fill, beam tilt or special wavelength spacing is provided.
- Antenna radiation aperture is the distance from the centre of the top bay to the centre of the bottom bay.
- Five ft(1.6mt) of pipe required above the top bay and below the bottom bay for to protect from pattern interference by other antennas.
- Antenna wind load is calculated for 100 Mph (160Km/h) per EIA-222-C standard.

"These specifications are subject to change without notice"