

Flat Panel

SmartMount®

Flat Panel TV Stand

For 32" to 50" LCD and Plasma Screens



MODELS

UNIVERSAL MODELS:

Standard Fasteners*

- SS550P** High gloss black with 2 tinted shelves
- SS550P -S** Silver with 2 tinted shelves
- SGLB01** Black with 1 clear shelf
- SGLS01** Silver with 1 clear shelf

SCREEN ADAPTER

UNIVERSAL MODELS:

Includes universal screen adapter to accommodate mounting holes spaced up to 28.75" horizontally and 17.05" vertically

SPECIFICATIONS

DIMENSIONS: (W x H x D)
40.15" x 57.63" x 25.53"
(102 x 146.4 x 64.8 cm)

TILT: -2°, 0°, +5°

MAX LOAD: 250 lb (113.3 kg)
150 lb screen (68 kg)
50 lb per shelf (22.6 kg)

SHIP WEIGHT:
SS models: 95 lb (43.1 kg)
SGL models: 85 lb (38.5 kg)

MOUNTING SURFACES: All floor surfaces



ACCESSORIES

pg#

- ACC317:** Tempered Glass Shelf (Clear glass, black bracket)153
- ACC317-S:** Tempered Glass Shelf (Clear glass, silver bracket).....153
- ACC318:** Tempered Glass Shelf (Tinted glass, black bracket)153
- ACC318-S:** Tempered Glass Shelf (Tinted glass, silver bracket)153
- ACC318-GB:** Tempered Glass Shelf (Tinted glass, high gloss black bracket).....153

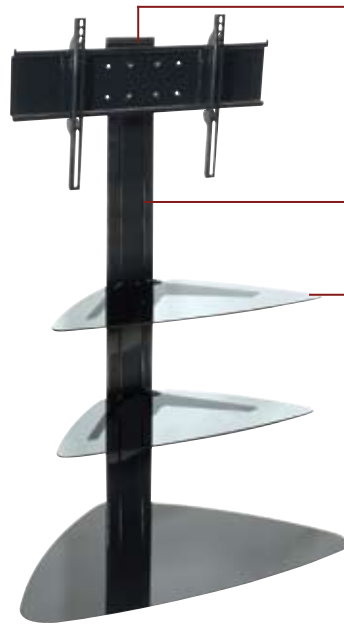

■ Designed to complement the look of any room with its modern colors and stylish design

■ Incremental tilt of -2°, 0° and +5° provides ideal screen angle

■ Continuous vertical adjustment for perfect viewing height

■ Adjustable tempered glass shelves to hold A/V components and accessories (additional shelf available)



■ Internal cable management neatly hides all cords and cables for a clean, clutter-free appearance

* Includes standard hardware (hex or Phillips) for attaching screen to mount

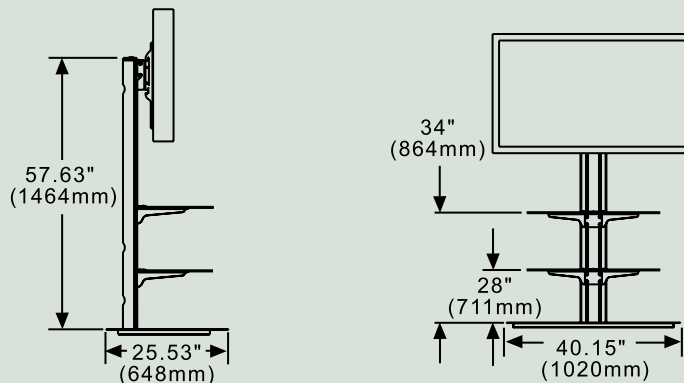

To verify mount compatibility with any LCD, plasma, or projector model use MountFinder™ at www.peerlessmounts.com 800.865.2112