



## FEATURES

- 1 CENTRIS™ FINGERTIP TILT**  
Provides smooth fingertip tilt in all directions using the screen's center of gravity. Screen angle stays set until you decide to re-adjust.
- 2 POST-INSTALLATION LEVELING**  
No tools needed. Ultra fast and easy screen positioning with lock down capability.
- 3 PORTRAIT/LANDSCAPE CAPABILITY**  
Mounts in either portrait or landscape position.
- 4 CABLE MANAGEMENT**  
Easily route cables through 1-1/2" NPT extension column.



## SPECIFICATIONS

Roll	360°
Tilt	+/-15°
Yaw	360°
Color	Black, Silver
Weight Capacity	40 lbs (18.1 kg)



## WHAT YOU NEED TO KNOW

### ORDERING OPTIONS

Available in custom or universal.

### OTHER PRODUCT OPTIONS



**FHP18110™**  
Ceiling Mount with 12 - 18" (30 - 46 cm) Extension



**FHP110™**  
Ceiling Mount with 24 - 46" (61 - 117 cm) Extension

## TECHNICAL DRAWINGS

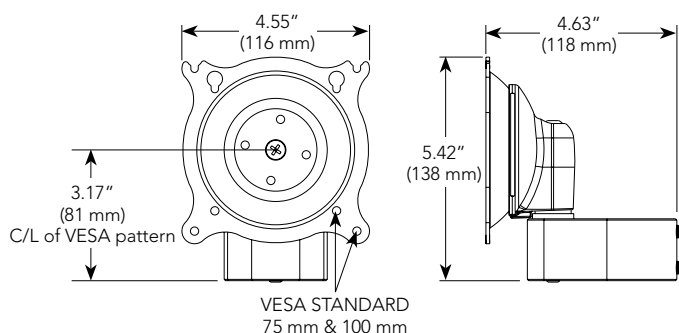

## RECOMMENDED ACCESSORIES



**CMA STRUCTURAL ADAPTERS**



**CMS EXTENSION COLUMNS**

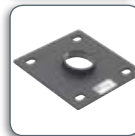

**CMA CEILING PLATES**

For a complete list of flat panel mount accessories see page 73.